

my skimmed barrel this dim= 4.058
 Compression increased from 6.75:1
 To approx 8.5:1 The bottom flange has
 been skimmed and the bore oiling holes
 relocated, the rod slot is standard so is the
 pigot.

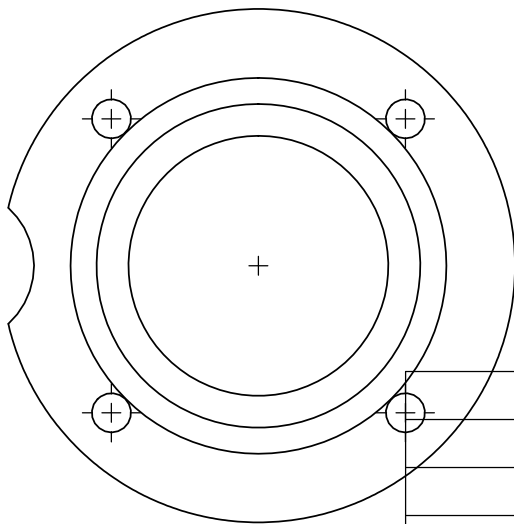

PROPRIETARY AND CONFIDENTIAL
 THE INFORMATION CONTAINED IN THIS
 DRAWING IS THE SOLE PROPERTY OF
 <INSERT COMPANY NAME HERE>. ANY
 REPRODUCTION IN PART OR AS A WHOLE
 WITHOUT THE WRITTEN PERMISSION OF
 <INSERT COMPANY NAME HERE> IS
 PROHIBITED.

		UNLESS OTHERWISE SPECIFIED:		NAME	DATE	
		DIMENSIONS ARE IN INCHES		DRAWN		
		TOLERANCES:		CHECKED		TITLE:
		FRACTIONAL ±		ENG APPR.		MAC barrel, un-skimmed
		ANGULAR: MACH ± BEND ±		MFG APPR.		
		TWO PLACE DECIMAL ±		Q.A.		
		THREE PLACE DECIMAL ±		COMMENTS:		
		INTERPRET GEOMETRIC				SIZE
		TOLERANCING PER:				DWG. NO.
		MATERIAL				REV
		FINISH				A mac-barreloriginal
NEXT ASSY	USED ON					SCALE: 1:5
						WEIGHT:
						SHEET 1 OF 1

Compression Ratio
When std MAC with 6.75:1 piston has the barrel Skimmed

